

HOWO Skip Loader Truck

6CBM capacity & Remote Wireless Control box

User's Manual



www.howotrucks.com/

Skip Loader Truck

OWNER'S MANUAL

Preface

Thank you for purchasing CS TRUCKS products. For better using your HOWO Skip Loader Truck, get the best operating performance, we strongly suggest that before the operation process you should read this manual instructions carefully, and to manipulate the program handily.

The manual detailed describes the performance of skip loader truck, structure, usage, precautions and maintenance of such knowledge. While showing details of the truck, both pictures and description will together help you get better understanding of how to use truck. Before the operation, the skilled operator should carefully read the contents of the manual.

After master the truck performance characteristics, methods of operation and precautions, then could start to operate this garbage truck. In order to ensure the staff turnover after the operation, and properly use of the truck. This manual book must be properly kept, shall not be lost and damage.

----CS TRUCKS

Contents

Chapter 1. General Description.....	5
Chapter 2, Main Technical Data	6
Chapter 3, What is Skip Loader Truck	7
i , Skip Loader Truck Advanced Feature	7
ii , Skip Loader Truck Working Principle	8
Chapter 4, How to Operate Skip Loader Truck	11
i ,Skip Loader Truck Introduction	11
ii ,Skip Loader Truck Operation Guidance (Very Important)	12
Chapter 5, Others for Attention	16
Chapter 6 Troubleshooting.....	17

Chapter 1. General Description

*CS TRUCKS Skip Loader Truck based on type II HOWO 4*2 LHD chassis, garbage container capacity could up to 6,000liters, mainly used for garbage collection, storage and transportation, and the working aerial can be city street, factory, community and other areas of need.*

*The vehicle designed to fully rely on the advantages of the original 4*2 left-hand-drive chassis, fully consider the product's convenience, reliability and features. The swing arm and rubbish container material is international standard steel, all with anti-rust painting, which can effective to avoid rusting. As for rubbish container capacity, this can be up to 3CBM and very suitable to meet customers' garbage transport requirement.*

*The HOWO 4*2 Skip Loader Truck equipped with Swing Arm and two hydraulic legs, which can be used carrying 3CBM garbage container. For one Skip Loader Truck, can be match used with several containers. And the garbage containers can be spread everywhere for rubbish collection. Therefore, the vehicle is an ideal Skip Loader Truck mainly for refuse collection & refuses transportation.*



(Preview for your HOWO 6cbm Skip Loader Truck)

Chapter 2, Main Technical Data

Basic parameter:

Items		6CBM HOWO Skip Loader Truck
S I Z E	Outer Dimension (L×W×H) (mm)	7100*2200*3250
	Wheelbase (mm)	4500
Kerb Weight (kg)		6400
G E A R	Gearbox brand	WLY6TS55
	Model	6-shift gearbox
	Type	Manual
Cab capacity (includes driver)		2
E N G I N	Model	CUMMINS ISF3.8s3154
	Type	Four cylinder inline, water-cool, turbocharged Inter-cooling, diesel
	Rating Power (kW/HP)	113/154
	Emission Standard	Euro 3

Note: 1. The vehicle height includes Swing Arm.

2. We keep the right to revise the parameters on the list above.

Skip Refuse System basic parameter list

Items		Parameter	
Control System		Hydraulic control system	
Swing Arm		High Strength steel material	
Hydraulic Legs		Double hydraulic legs at rear for support	
G a r b a g e C o n t a i n e r	Capacity (CBM)	6	
	Material	Standard Carbon Steel	
	Painting	Internal	With anti-rust painting
		External	White painting with Logos
	Dimension	Length (mm)	3200
		Width (mm)	1600
Height (mm)		1300	

Chapter 3, What is Skip Loader Truck

i , Skip Loader Truck Advanced Feature

CS TRUCKS produce Skip loader truck also named skip refuse truck, swing arm garbage truck. This based on famous HOWO brand truck chassis, refitted with special upper structure. As for the component, including Swing Arm System, Hydraulic System, Control System, Container, etc. Technical drawing with dimension as following:

Swing Arm System: The material for swing arm is high strength steel, which was welded based on chassis dimension. Operating the Multi-way Valve can control hydraulic cylinder to move, which can control the swing arm rotating, the maximum swing angle can be up to 145°. The Swing Arm System can be used loading & unloading container.

Hydraulic System: The Skip Loader Truck totally controlled by hydraulic system, including swing arm rotating, hydraulic legs stretch out and draws back.

Operation System: Control PTO to transit power to oil pump work, then operating the multi-way control valve joysticks to make swing arm and hydraulic legs working, and can control the garbage container loading and unloading.

Container: The material is high strength steel, and model is standard type with no cover. When bulk rubbish throws into the container, hang up the sling chain to container, then operating multi-way control valve to load and unload container. For one truck can match with tens of container at one time. Detail construction for one container as follow:

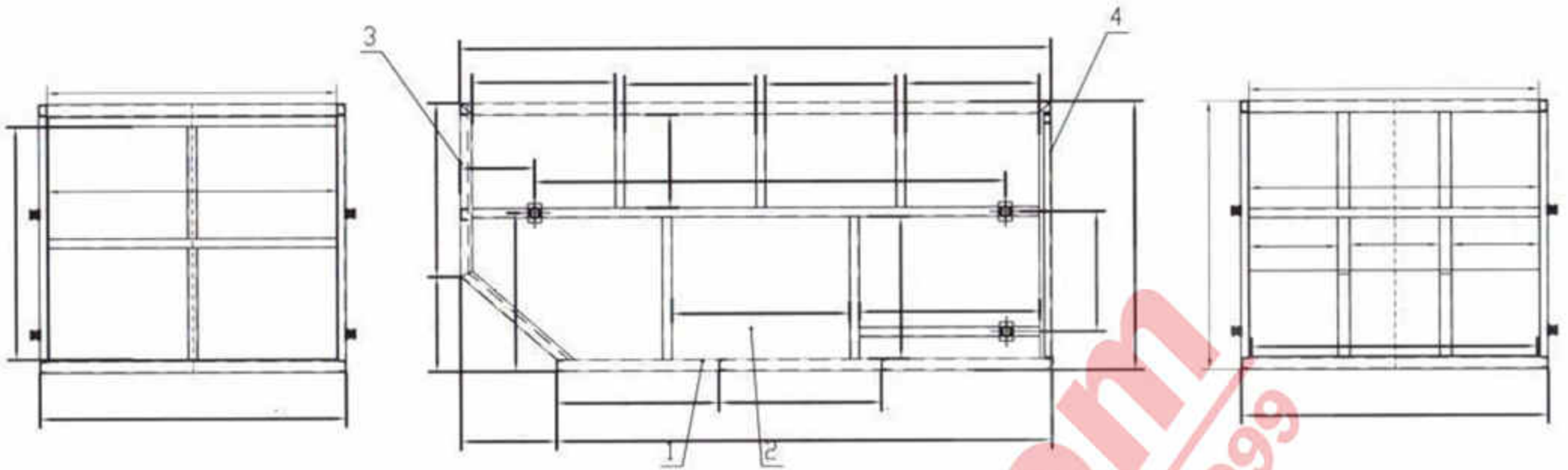

Items	Name	Quantity
1	Side Plate Assembly	2
2	Bottom Plate Assemble	1
3	Rear Door Assembly	1
4	Front Plate	2
5	Front Plate Channel Plate	4
6	Rear Door Hook	2

ii, Skip Loader Truck Working Principle

As for hydraulic control system, which including oil tanker, oil pump, multi-way control valve, hydraulic cylinder, balancing valve, hydraulic leg lock, oil filter, pipeline system, etc.

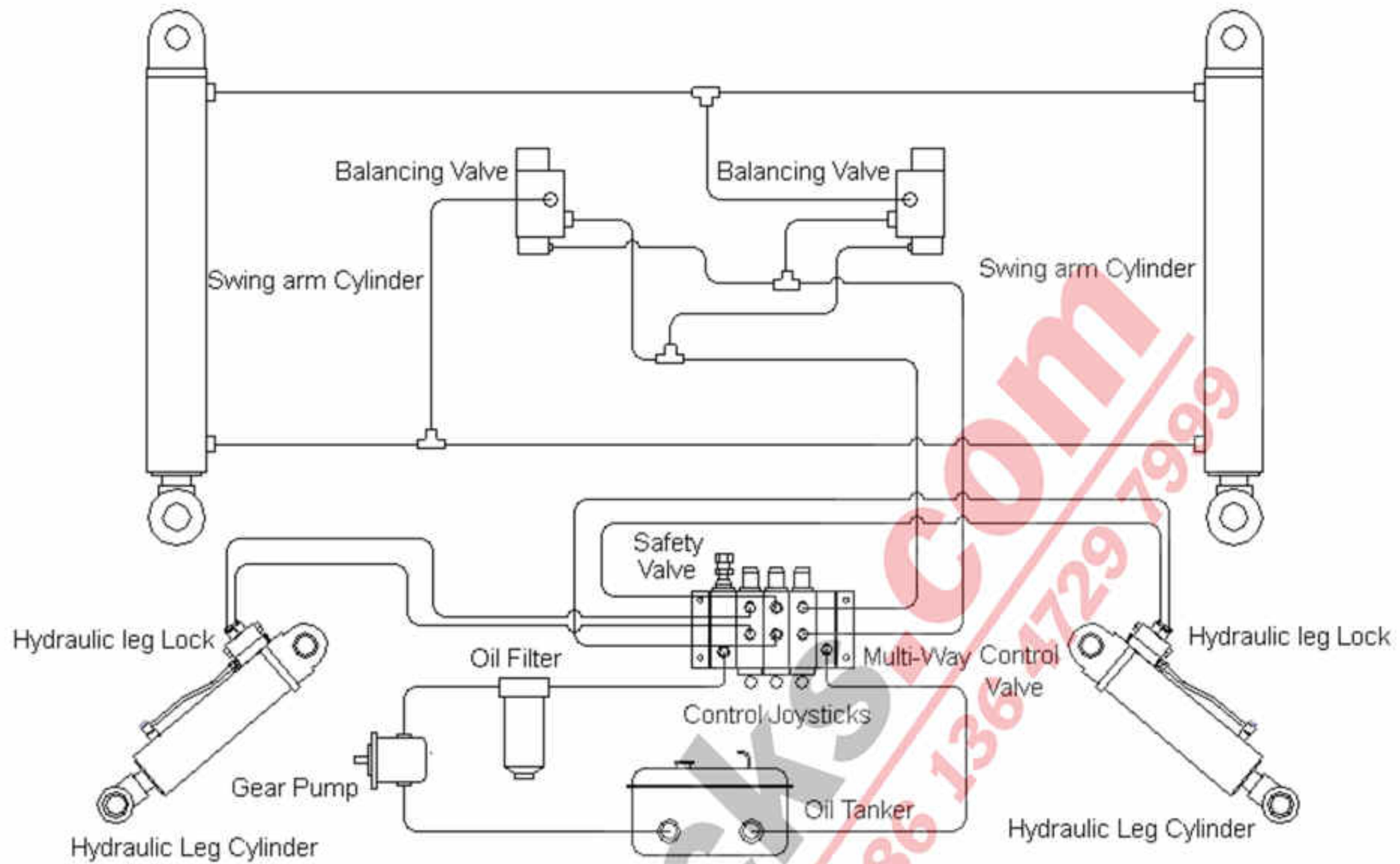

The PTO (Power Take Off) gets power from Truck Engine, then transit power to Oil Pump through transmission shaft, the Oil Pump start working, Multi-way Control Valve can control the swing arm and hydraulic legs working, which can match with refuse container loading and un-loading, then realize the garbage collection and transportation job.

The Hydraulic system equipped with Balancing Valve & Hydraulic Lock. To be more specific, Balancing Valve ensures the swing arm working more smoothly and safety, which can efficiently prevent garbage container loading and unloading too fast or too slow. Hydraulic Lock can protect the hydraulic legs during working.

When not operating Multi-way Control Valve and Control Joysticks, the hydraulic oil will flow back to oil tank through Multi-way Control Valve.

The Maximum working pressure for Hydraulic System is 16MPa, this pressure is limited by safety valve

on Multi-Way Control Valve. Frankly speaking, when hydraulic system working pressure over 16MPa, the hydraulic oil will through safety valve back to oil tank, means the truck is over loading, the hydraulic system cannot working properly.

Please note that the Safety Valve has been set in factory, do not adjust anything!

howotrucks.com
whatsapp: 0086 136 4729 7999

Chapter 4, How to Operate Skip Loader Truck

i ,Skip Loader Truck Introduction

Overviews for HOWO 6 CBM skip loader truck technical drawing:

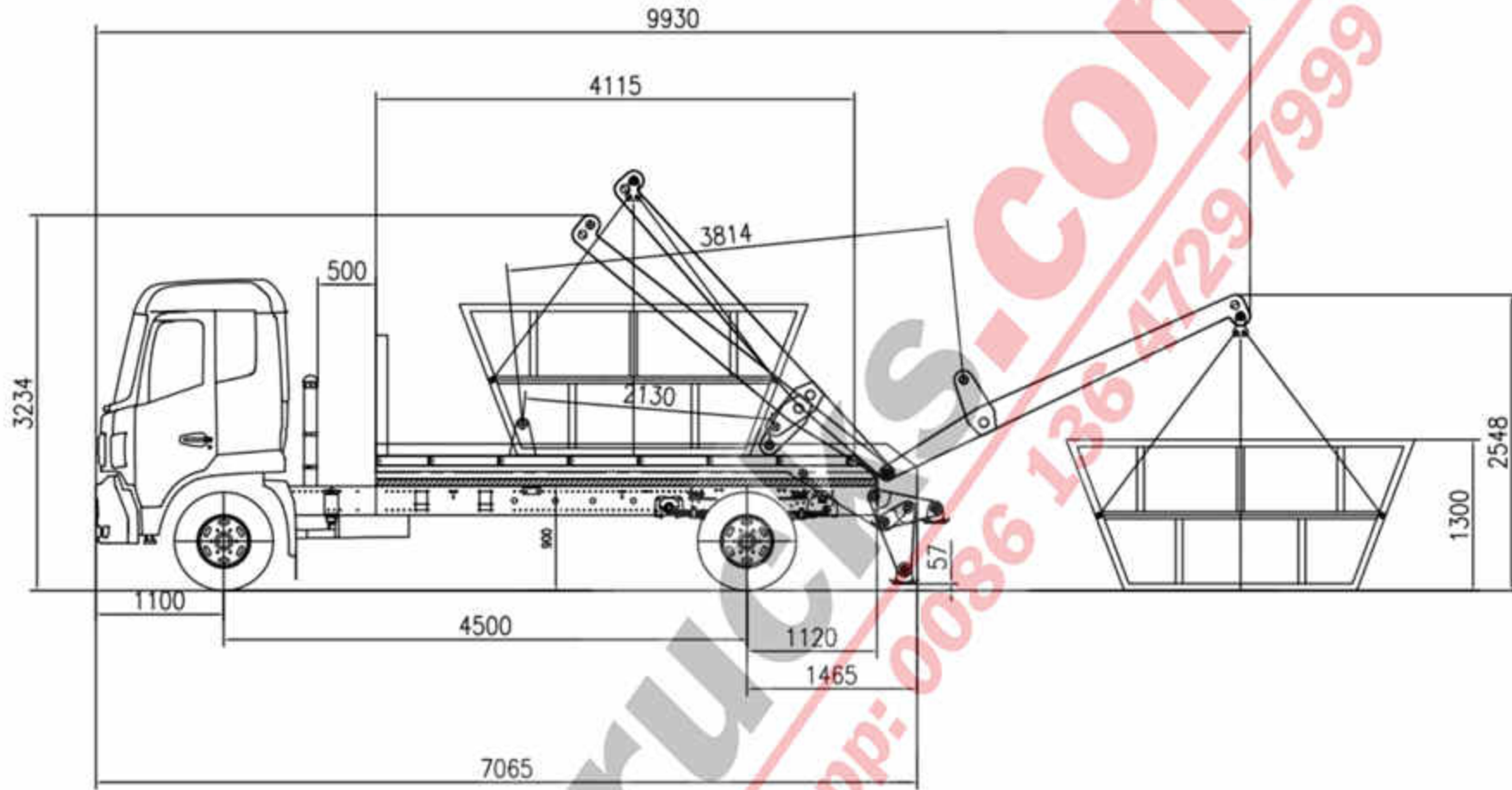

Hydraulic System: Swing arm hydraulic cylinder & Hydraulic cylinder





Garbage Container: Details please reference Chapter 3 part one

Hydraulic oil Tank: Located between truck cabin and super structure

Hydraulic Control System: Multi-way control valve joysticks and pressure instrument panel

ii ,Skip Loader Truck Operation Guidance (Very Important)

- 1、 **The Preparation for Operation:** Carefully checking the operation environment, make sure no person stand around the truck, also do not forget pull the Parking Brake before any operation.
- 2、 **PTO Operation:** Before operating the swing arm system, please make sure the PTO is working. Detail operation process should as follow, firstly start the truck engine and depress the clutch panel, secondly close the PTO switch, thirdly slowly loosen the clutch panel, then the oil pump start working.

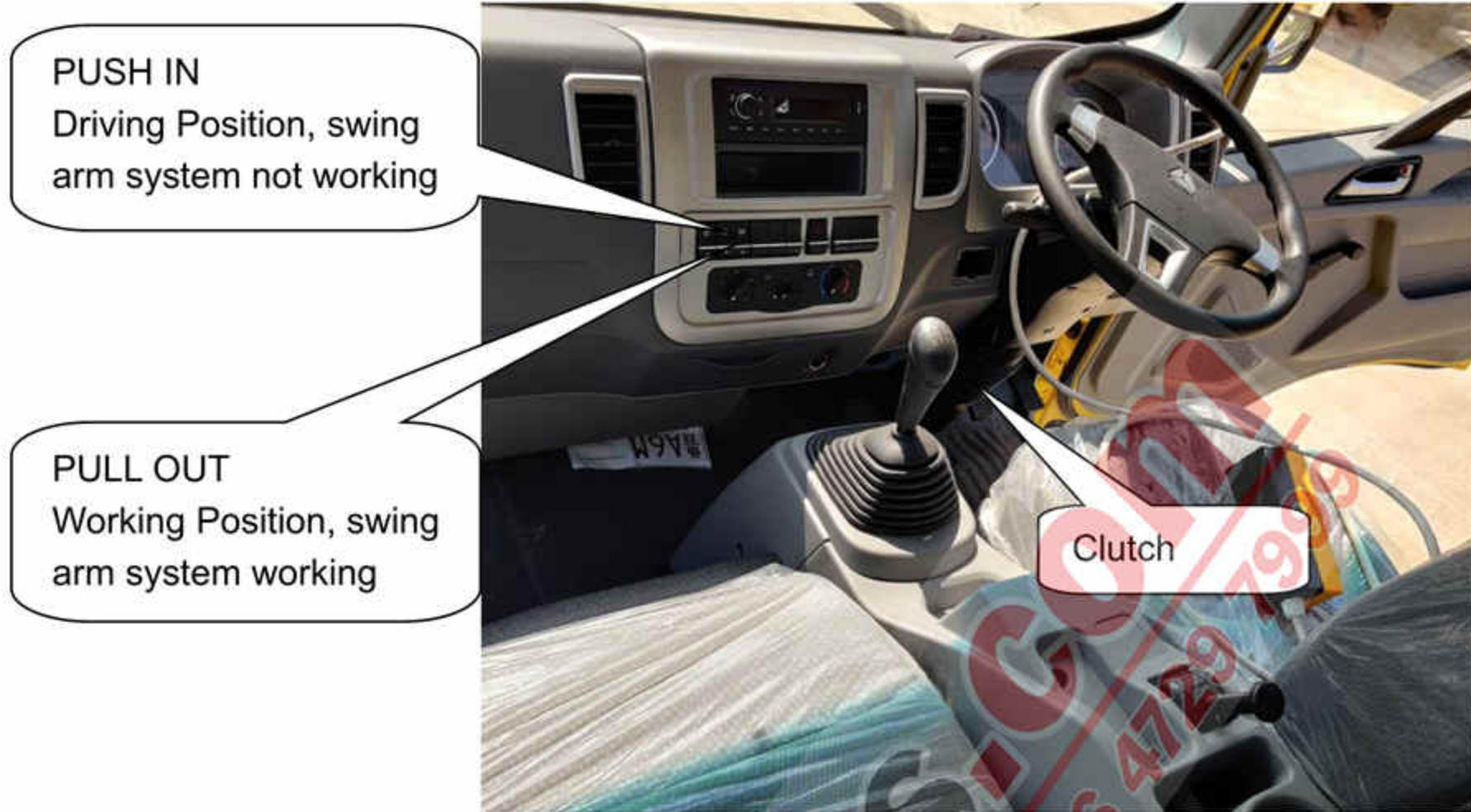

NOTE: Please keep the Accelerator handle Cable at Driving Position while driving the truck!
 Please does not operating the swing arm system while driving the truck!

3. **Hydraulic Legs Operation:** Operating multi-way control joysticks one & two **together** to stretch hydraulic legs, only when the double hydraulic legs stabilized then can start other process.

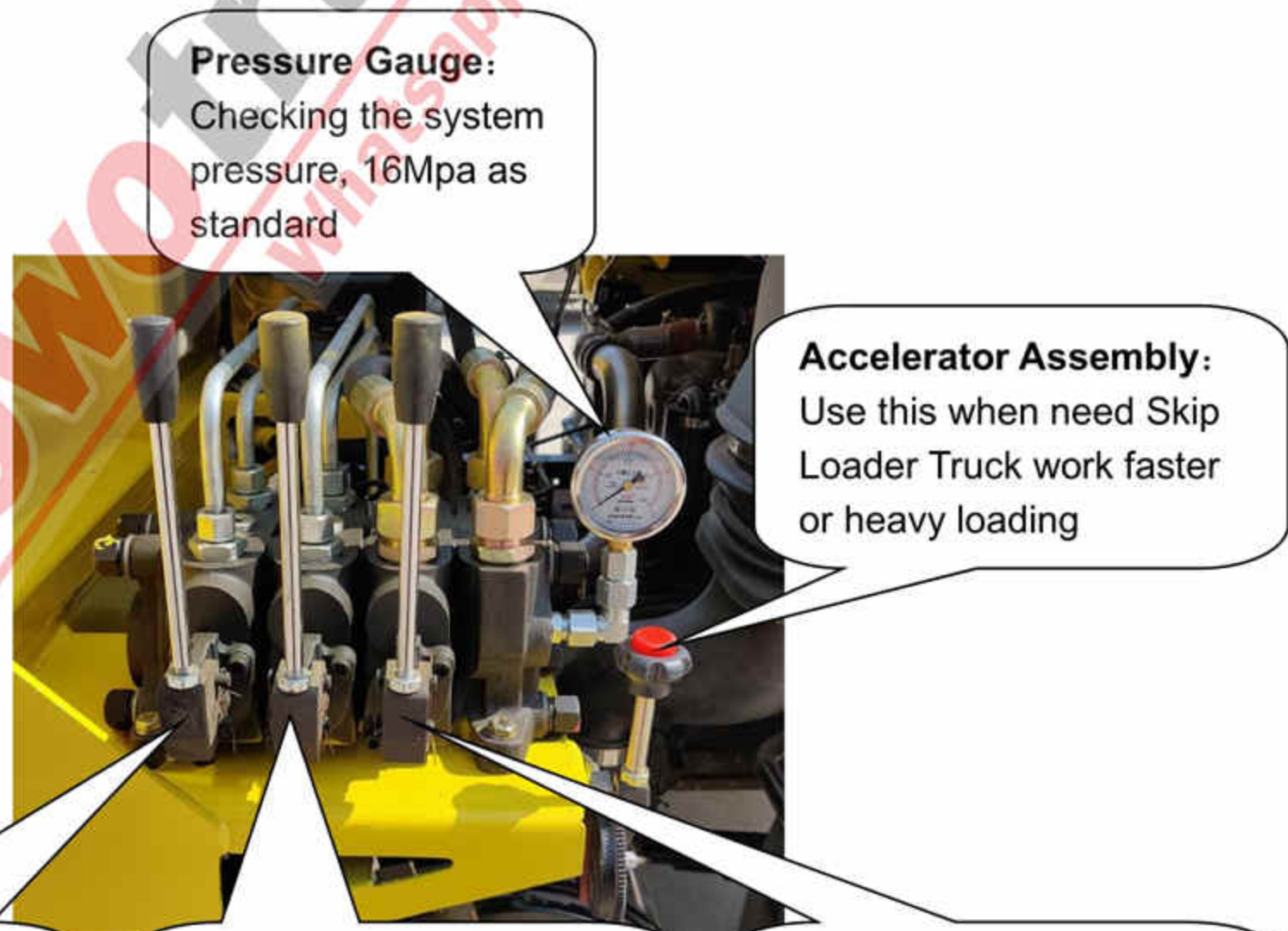

Pressure Gauge:
 Checking the system pressure, 16Mpa as standard

Accelerator Assembly:
 Use this when need Skip Loader Truck work faster or heavy loading

Left Joystick:
 Control Rear right hydraulic leg Reach & Retract

Middle Joystick:
 Control Rear left hydraulic leg Reach & Retract

Right Joystick:
 Control Swing Arm System Rise & Drop

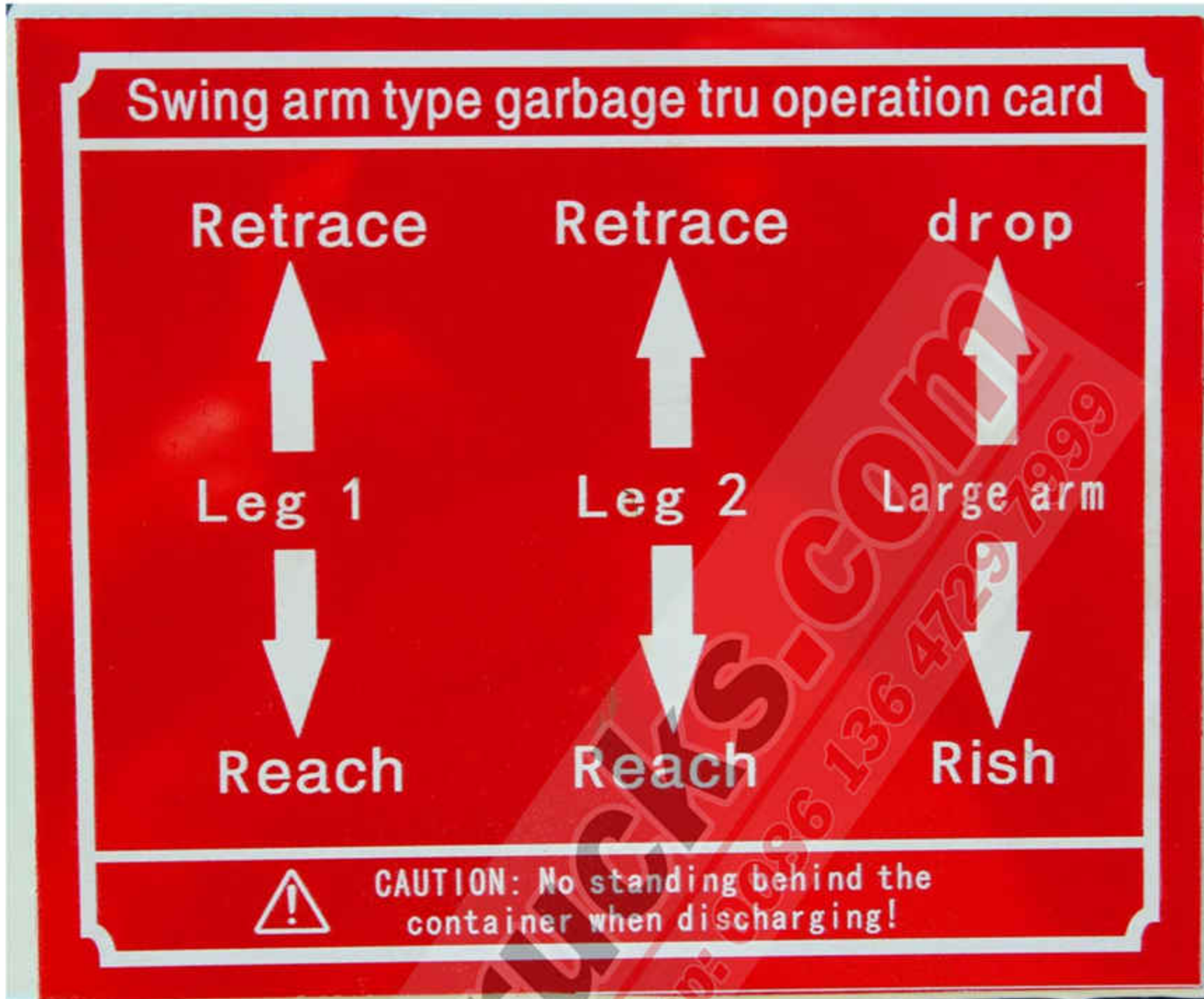

Customized Remote Wireless Control Device

4. **Container Loading Operation:** Hang up the hinge chain connect with the container, operating the multi-way control joysticks three to loading and unloading the garbage container. Please note that the hinge chain is relaxation mode when container on the truck.

Left Joystick: Pull → Left side hydraulic leg Stretch Out

Push → Left side hydraulic leg Retract Back

Middle Joystick: Pull → Right side hydraulic leg Stretch Out

Push → Right side hydraulic leg Retract Back

Right Joystick: Pull → Swing arm rotating to load container

Push → Swing arm rotating to unload container



NOTE: When Reach & Retract rear hydraulic legs, Left and Middle Joysticks should be operated together!

5. **Garbage Transportation Operation:** Stop the oil pump and PTO, make sure the truck hydraulic system not working during transportation.

6. **Garbage Discharging Operation:** Following the above direction to unload garbage.

Chapter 5, Others for Attention

After carefully reading the above information, you must be well known how to use the HOWO Skip Loader Truck; below show some parts you need to pay attention while using the truck.

- 1. Please strictly follow the Operation Manual, and note that only skilled worker can be allowed operate the Skip Loader Truck.*
- 2. Carefully checking the working environment, if the working place is slope with angle over 12%, you need to use block brake the wheel.*
- 3. Keep nobody stand around when operating the skip loader truck.*
- 4. Before operating the swing arm system to load and unload the rubbish container, make sure the hydraulic legs are stretch out and stand stabilized.*
- 5. Please do not adjust the hydraulic oil pressure, for which has been set in factory.*
- 6. Please strictly follow the Owner's Manual to operate the skip loader truck. If any unusual phenomenon happens during operation, you should stop the working immediately and carefully found out the reason, only when the troubleshooting then you can restart working.*
- 7. The Hydraulic Oil should keep clean during working, if the oil becomes dirty, please kindly change the oil to make sure the truck can work smoothly.*

Chapter 6 Troubleshooting

Malfunction	Possible Reason	Solution
Oil Cylinder Piston Rod Oil leakage	<ol style="list-style-type: none"> 1. Sealing ring damage 2. Surface of the piston rod scratch 	<ol style="list-style-type: none"> 1. Carefully checking the sealing ring, change new one if necessary 2. Use sandpaper burnish it, change new one if necessary
Piston Rod Movement is Crawl or Peristalsis	<ol style="list-style-type: none"> 1. Hydraulic cylinder or hydraulic oil mixed with air 	<ol style="list-style-type: none"> 1. Eliminate air
The Hydraulic Cylinder Lifting Powerless	<ol style="list-style-type: none"> 1. Piston sealing element damage 2. System pressure too low (The safety valve imbalance) 3. System pressure too low (The internal leakage) 4. Oil pump damage 5. Hydraulic oil storage shortage 6. Oil filter blocked 	<ol style="list-style-type: none"> 1. Checking & replace the sealing element 2. Checking & adjust the safety valve pressure 3. Checking & replace the element 4. Checking & replace oil pump 5. Checking & refueling hydraulic oil 6. Checking & replace oil filter
Hydraulic legs Powerless	<ol style="list-style-type: none"> 1. Hydraulic lock leakage 2. Cylinder piston rod sealing element damage 	<ol style="list-style-type: none"> 1. Cleaning & replace the element 2. Checking & replace the sealing element
External Leakage	<ol style="list-style-type: none"> 1. Sealing ring damage 2. Oil pipeline surface damage 	<ol style="list-style-type: none"> 1. Checking & replace new sealing ring 2. Checking & replace new pipeline

Please kindly checking below possible troubleshooting, which just for your reference.